



DTA

Damen Technical Agencies



Mobile Hydraulic Pumps T6GCC

Denison Vane Technology, fixed displacement

Hydraulic Pumps

Hydraulic Motors

Hydraulic Valves

Hydraulic Cylinders

Hydraulic Filtration

Hydraulic Accumulators



ENGINEERING YOUR SUCCESS.

We are doing our parts to keep you moving!

DTA your 1 Stop Shop for Hydraulics, Pneumatics and Power Transmissions.

DECLARATION OF CONFORMITY

DTA Hydraulics is a tradename of Damen Technical Agencies BV, supplying hydraulic parts to various industries since 1990. As a Certified Distributor Hydraulics by Parker Hannifin and Authorized Denison Vane Pump Assembler, we guarantee the use of original parts and components. As such we provide you with vane pumps of the same level of quality and warranty conditions as the factory does.

We highly recommend to **use genuine Denison Hydraulics spare parts only** in order to ensure smooth operation and longer service life. Spare parts that we have on stock include pump cartridge kits, shaft and bearing assemblies, seal kits and non-wearing parts of both the T6 and T7 series vane pumps.



**ALL VANE PUMPS SUPPLIED OR REPAIRED BY
DTA HYDRAULICS HAVE BEEN ASSEMBLED ACCORDING
TO THE LATEST FACTORY SPECIFICATIONS WITH
BRAND NEW AND GENUINE DENISON HYDRAULICS PARTS**

We are able to provide you a large variety of options of the original Parker Denison single, double, and triple vane pumps. We can build any customized vane pump from our stock of genuine parts. You can now easily configure that vane pump yourself with the Denison Hydraulics Vane Pump Configurator.

vanepump.eu/vanepumps

Use advanced search to filter results based on configurable options and select any of the 25,000 vane pumps that are listed in our online catalogue. Most of the models are available from stock and ready for shipment to any place in the world instantly. We can supply **Any part, Anytime, Anywhere!**



Model No.

T6GCC - B22 - B08 - 6 R 00 - B 1 - 00

Series



Cam ring for "P1" & "P2"

(Delivery at 0 bar & 1500 r.p.m.)
 B03 = 16,2 l/min B17 = 87,4 l/min
 B05 = 25,8 l/min B20 = 95,7 l/min
B06 = 31,9 l/min B22 = 105,4 l/min
 B08 = 39,6 l/min B25 = 118,9 l/min
 B10 = 51,1 l/min **B28 = 133,2 l/min**
 B12 = 55,6 l/min B31 = 150,0 l/min
 B14 = 69,0 l/min

Type of shaft

6 = splined (DIN 5462)

Direction of rotation (view on shaft end)

R = clockwise

L = counter-clockwise

Modification

Mounting W/connection variables

	P1 = 1" - S = 3"	P1 = 1" - S = 2.1/2" ²⁾		
Code	00-0M	01-M0	10-1M	11-M1
P2	1"	3/4" ¹⁾	1"	3/4" ¹⁾

0 = UNC thread M = metric thread

¹⁾ for 46 ml/rev. max.

²⁾ for 126 ml/rev. max.

The larger cartridge must always be mounted in the front.

Seal class

1 = S1 - BUNA N

Design letter

Porting combination

00 = standard

P = Pressure port
S = Suction port

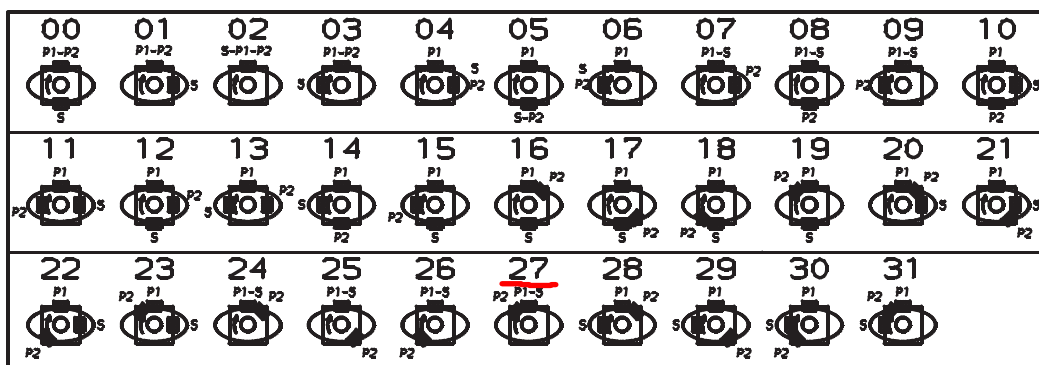

OPERATING CHARACTERISTICS - TYPICAL [24 cSt]

Series	Volumetric Displacement Vi	Speed n [R.P.M.]	Flow Q [l/min]			Input power P [kW]		
			p = 0 bar	p = 140 bar	p = 240 bar	p = 7 bar	p = 140 bar	p = 240 bar
B03	10,8 ml/rev	1000 1500	10,8 16,2	- 10,7	- -	1,0 1,3	- 5,3	- -
B05	17,2 ml/rev	1000 1500	17,2 25,8	11,7 20,3	- 15,8	1,1 1,4	5,1 7,5	- 12,2
B06	21,3 ml/rev	1000 1500	21,3 31,9	15,8 26,5	11,3 22,0	1,1 1,5	6,0 8,9	10,0 14,7
B08	26,4 ml/rev	1000 1500	26,4 39,6	20,9 34,1	16,4 29,6	1,2 1,6	7,2 10,7	12,1 17,7
B10	34,1 ml/rev	1000 1500	34,1 51,1	28,6 45,7	24,1 41,2	1,3 1,7	8,9 13,4	15,1 22,3
B12	37,1 ml/rev	1000 1500	37,1 55,6	31,6 50,2	27,1 45,7	1,3 1,7	9,6 14,4	16,3 24,1
B14	46,0 ml/rev	1000 1500	46,0 69,0	40,5 63,5	36,0 59,0	1,4 1,9	11,7 17,6	19,9 29,5
B17	58,3 ml/rev	1000 1500	58,3 87,4	52,8 82,0	48,3 77,5	1,6 2,1	14,5 21,9	24,8 36,9
B20	63,8 ml/rev	1000 1500	63,8 95,7	58,3 90,2	53,8 85,7	1,6 2,2	15,8 23,8	27,0 40,2
B22	70,3 ml/rev	1000 1500	70,3 105,4	64,8 100,0	60,3 95,5	1,7 2,3	17,3 26,1	29,6 44,1
B25 ¹⁾	79,3 ml/rev	1000 1500	79,3 118,9	73,8 113,5	69,3 109,0	1,8 2,5	19,3 29,2	33,2 49,5
B28¹⁾	88,8 ml/rev	1000 1500	88,8 133,2	83,3 127,7	80,1²⁾ 124,5²⁾	1,9 2,8	21,9 32,7	32,5²⁾ 48,5²⁾
B31 ¹⁾	100,0 ml/rev	1000 1500	100,0 150,0	94,5 144,5	91,3 ²⁾ 141,3 ²⁾	2,0 2,8	24,4 36,5	36,4 ²⁾ 54,4 ²⁾

¹⁾ B25 - B28 - B31 = 2500 R.P.M. max.

²⁾ B28 - B31 = 210 bar max. int.

- Not to use if the internal leakage is greater than 50% of the theoretical flow.

INTERNAL LEAKAGE (TYPICAL)

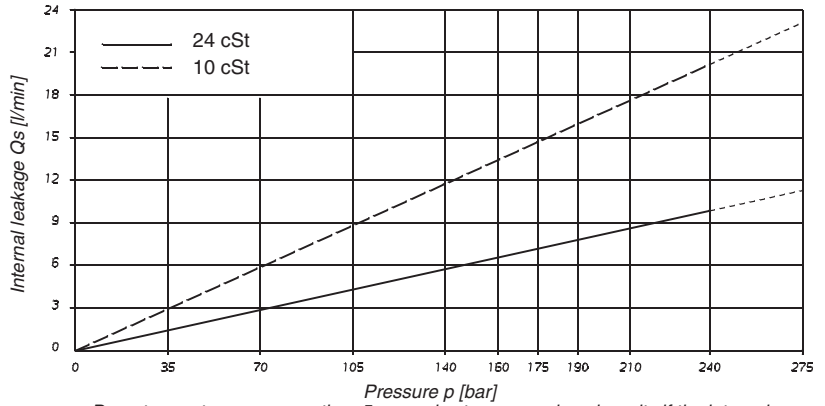

NOISE LEVEL (TYPICAL)
T6GCC - B22 - B22

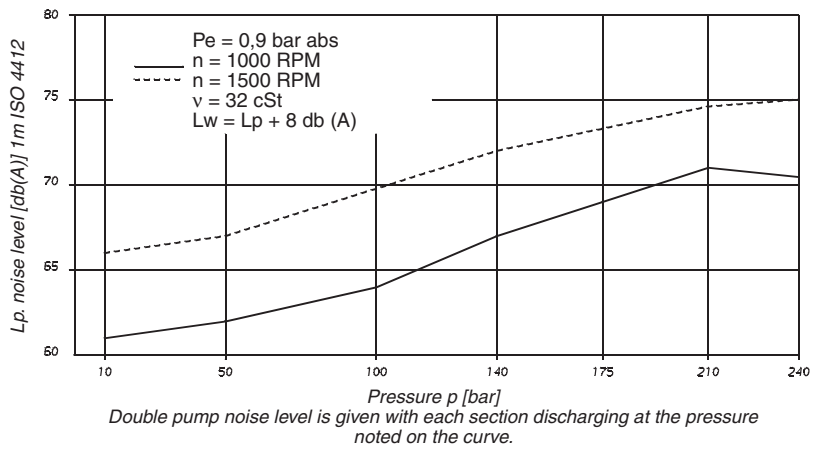

POWER LOSS HYDROMECHANICAL (TYPICAL)

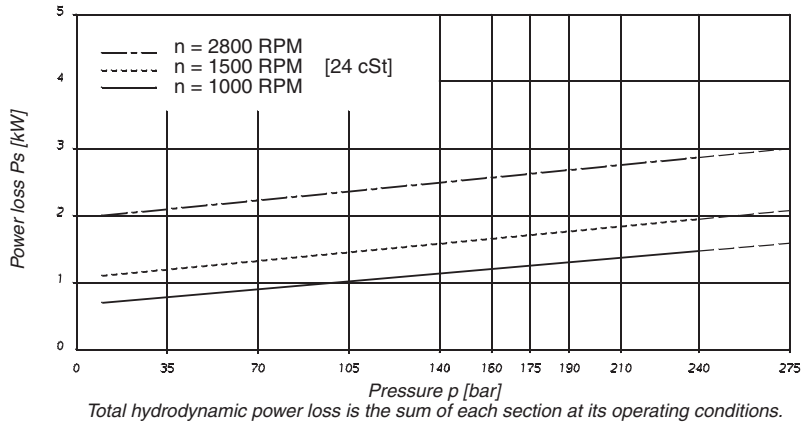

PERMISSIBLE RADIAL LOAD - T6GCC

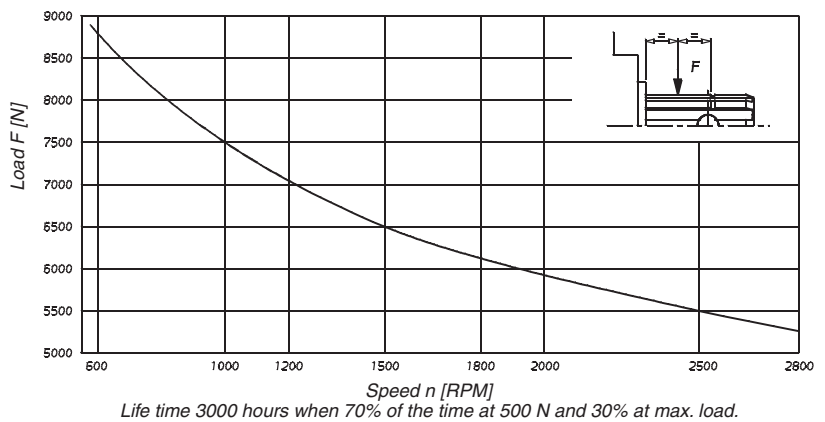

Weight 27.2 kg

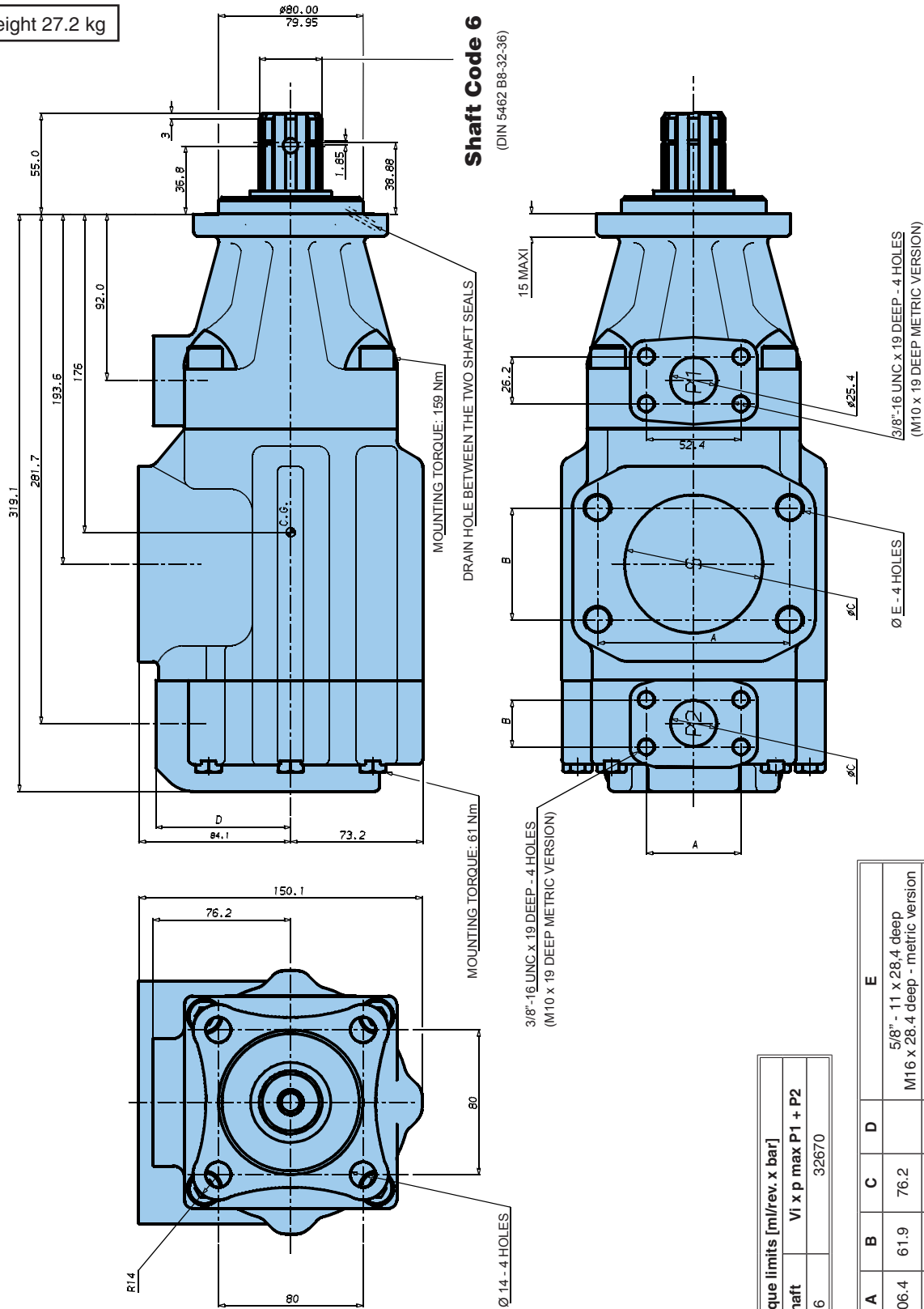

Shaft torque limits [ml/rev. x bar]	
Pump	Shaft
T6GCC	6
V1 x p max P1 + P2	
32670	

Port	Code	A	B	C	D	E
S	3"	106.4	61.9	76.2		5/8" - 11 x 28.4 deep M16 x 28.4 deep - metric version
S	2. 1/2"	88.9	50.8	63.5		1/2" - 13 x 23.9 deep M12 x 23.9 deep - metric version
P1	1"	52.4	26.2	25.4	76.2	
P2	3/4"	47.7	22.4	19.0	76.2	
P2	1"	52.4	26.2	25.4	74.7	



DTA

Damen Technical Agencies

ANY PART TIME WHERE

we are doing our parts to keep you moving!

Damen Technical Agencies B.V.

Prins Willemstraat 10 - 4791 JR Klundert - The Netherlands

+31 - 168 - 407 144

info@vanepump.eu - vanepump.eu - dta.eu



DTA

Damen Technical Agencies